

# Case Study in Placebo Modeling and Its Effect on Drug Development

## Modeling and Simulation Strategy for Phase 3 Dose Selection of Dasotraline in Patients With Attention-Deficit/Hyperactivity Disorder

Julie A Passarell, MA  
Executive Director of Statistics,  
Cognigen Corporation, a *SimulationsPlus* Company

**Cognigen**

 A SIMULATIONS PLUS COMPANY

# Background

- ADHD (attention-deficit/hyperactivity disorder) is a neurodevelopmental disorder characterized by symptoms of inattention, hyperactivity, and impulsivity associated with clinically significant impairment in functioning
- Dasotraline  
[(1R,4S)-4-(3,4-Dichlorophenyl)-1,2,3,4-tetrahydronaphthalen-1-amine]
  - novel compound in clinical development for treatment of ADHD
  - is potent inhibitor of human dopamine transporters (DAT) and norepinephrine transporters (NET), and weaker inhibitor of human serotonin transporters (SERT)
  - pharmacokinetic (PK) profile of slow absorption/elimination is unique among current stimulant and non-stimulant medications indicated for ADHD, and allows for once daily dosing

# Objectives

- Define dasotraline benefit-risk relationships by characterizing time-course and exposure-response (E-R) relationships between dasotraline and improvement in severity of ADHD symptoms as measured by ADHD Rating Scale-IV (RS-IV) using Phase 2 data in adults
- Perform clinical trial simulations to predict probability of success for Phase 3 study designs

# Methodology

- Sequential pharmacokinetic/pharmacodynamic (PK/PD) approach:  
1) population PK modeling, 2) generation of individual dasotraline exposures, and 3) E-R modeling of ADHD RS-IV total scores

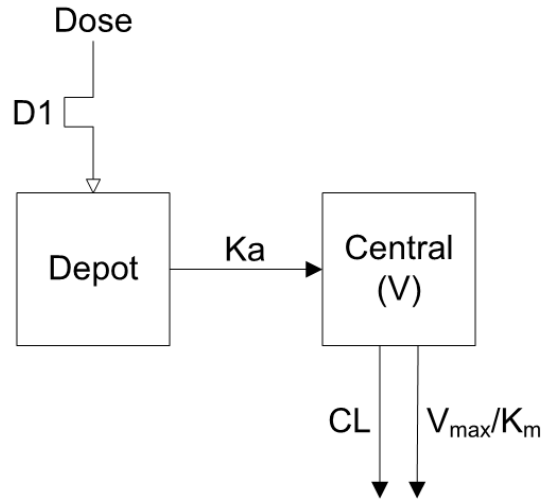

 Zero-order input

- Integration used to calculate individual dasotraline exposures at each week
  - Average concentration within a dosing interval ( $C_{av}$ )
  - Area under the concentration-time curve from time 0 to 24 hours ( $AUC_{0-24}$ )
  - Minimum drug concentration ( $C_{min}$ ), and
  - Maximum drug concentration ( $C_{max}$ )

# Methodology

## ADHD RS-IV Data

- Primary efficacy endpoint - ADHD Rating Scale, Version IV (ADHD RS-IV) total scores
  - widely used as a measure of efficacy in clinical trials of ADHD treatments
  - Parent, teacher, and adult versions
  - Adult prompts used in adult Phase 2 study
- 18-item scale provides a rating of the severity of symptoms
  - First 9 items assess inattentive symptoms
  - Last 9 items assess hyperactive-impulsive symptoms
- The adult prompts serve as a guide to explore more fully the extent and severity of ADHD symptoms and create a framework to ascertain impairment

# Methodology

## ADHD RS-IV Data, cont'd

- Scoring is based on a 4-point Likert-type severity scale:
  - 0 = none symptoms, 1 = mild, 2 = moderate, 3 = severe symptoms
  - Total range of 0 to 54
- Significant symptoms in clinical trials are generally considered at least a “2” – moderate
- What change in ADHD RS-IV total scores is clinically meaningful?
  - No explicit amount of change is deemed meaningful
  - However, placebo data plays an integral role as the comparator arm in determining if a drug demonstrates efficacy using statistical significance testing

# Methodology

## E-R Modeling of ADHD RS-IV

- ADHD RS-IV total score data (screening, baseline, and weekly for 4 weeks on treatment) from 1 adult Phase 2 study
- 1847 ADHD RS-IV measurements from 330 patients
  - 33% placebo, 34% 4 mg/day, and 33% 8 mg/day
- Covariates evaluated: age, race, sex, baseline weight, baseline body mass index, baseline ADHD RS-IV, and baseline insomnia severity index

# E-R Modeling Process for ADHD RS-IV

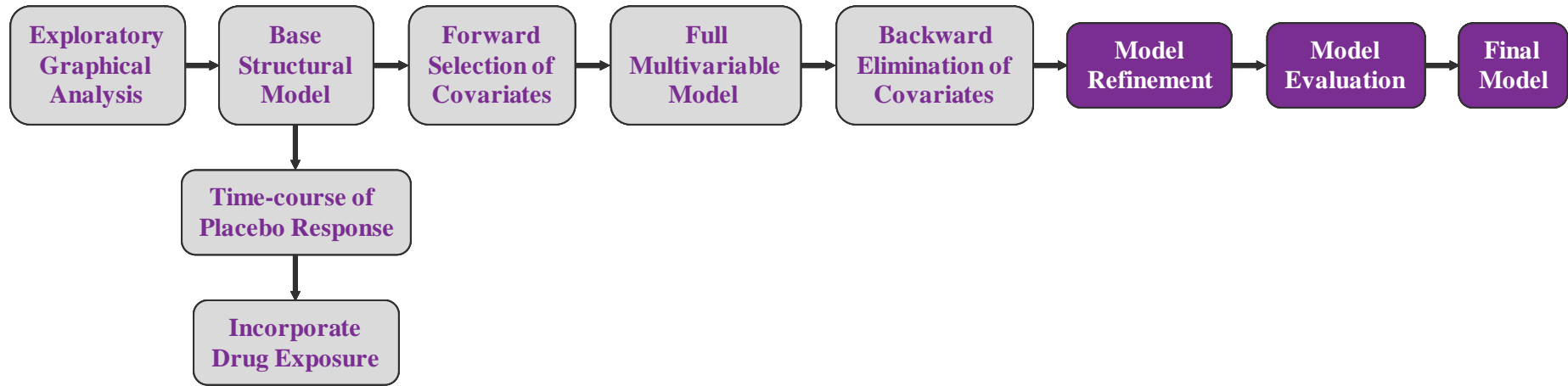

$$ADHD\ RS - IV = baseline + f(placebo\_response) + f(drug\_effect)$$



# RESULTS

# E-R Exploratory Data Analysis

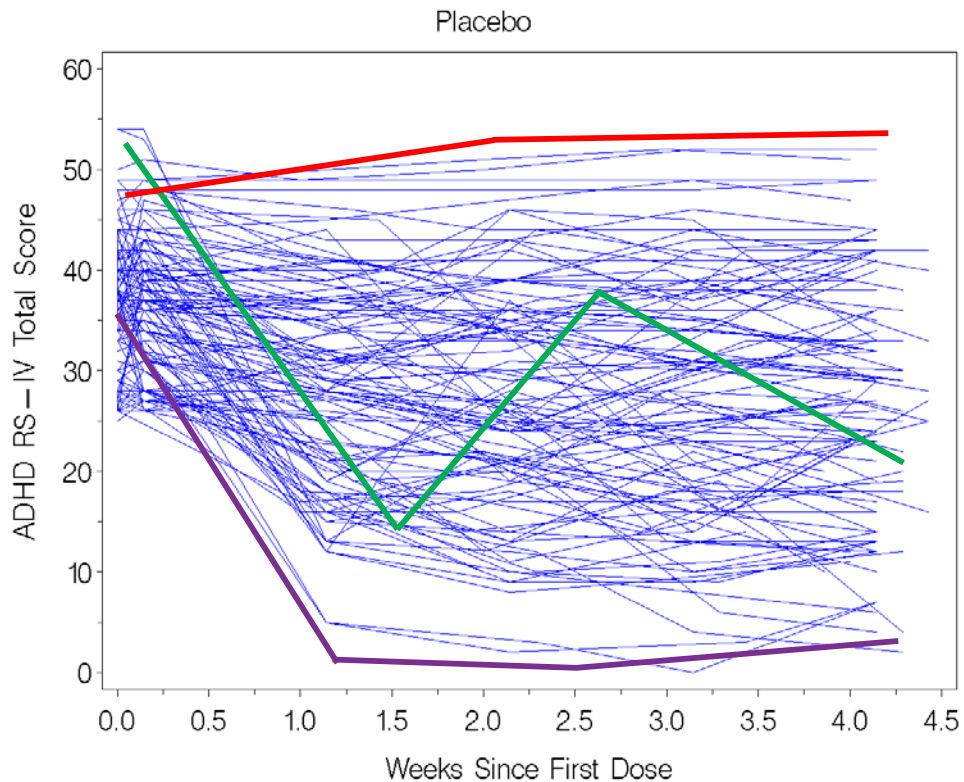

Large variability across patients.

# E-R Exploratory Data Analysis, cont'd

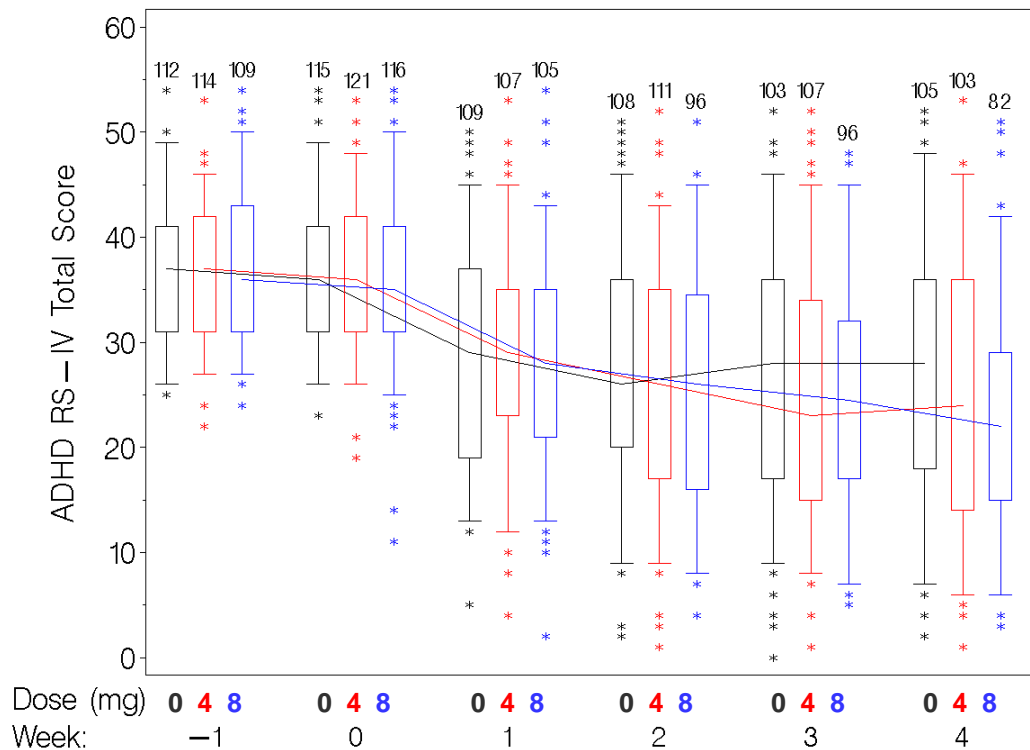

Boxes are 25th, 50th, and 75th percentiles; whiskers extend to the minimum and maximum values. The number of patients is above each box.

# E-R Exploratory Data Analysis, cont'd

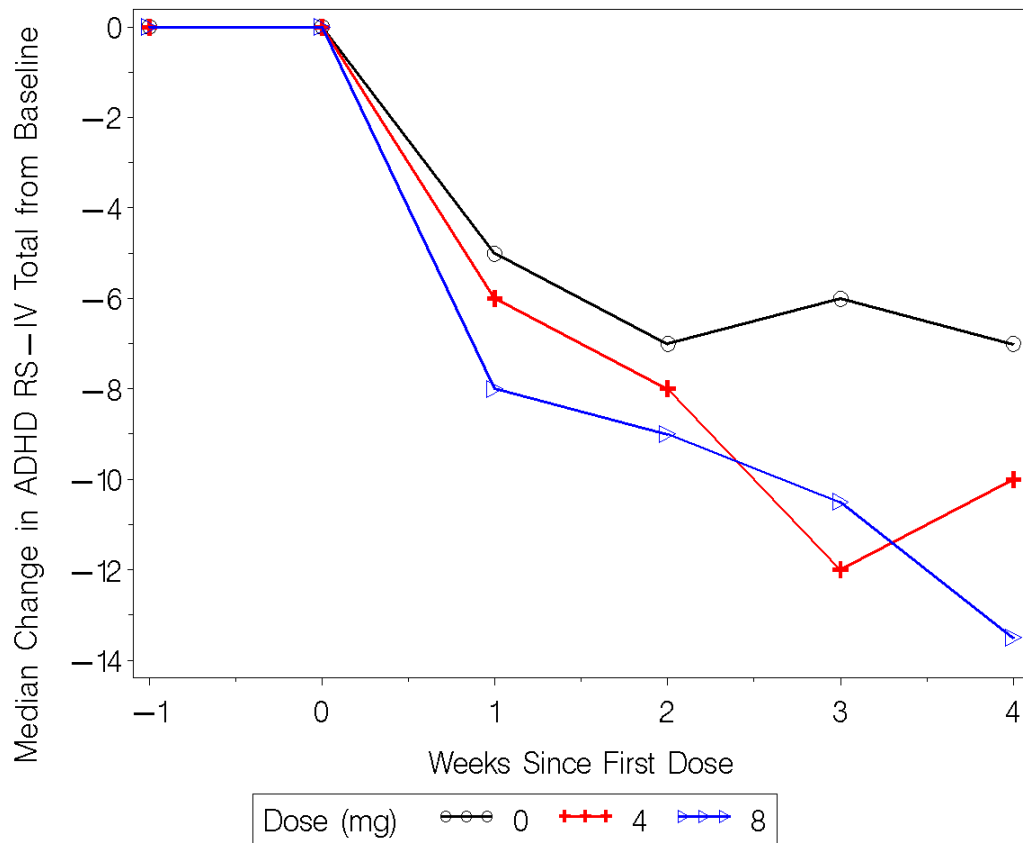

# ADHD Placebo Response Model

## Time-course Models Tested

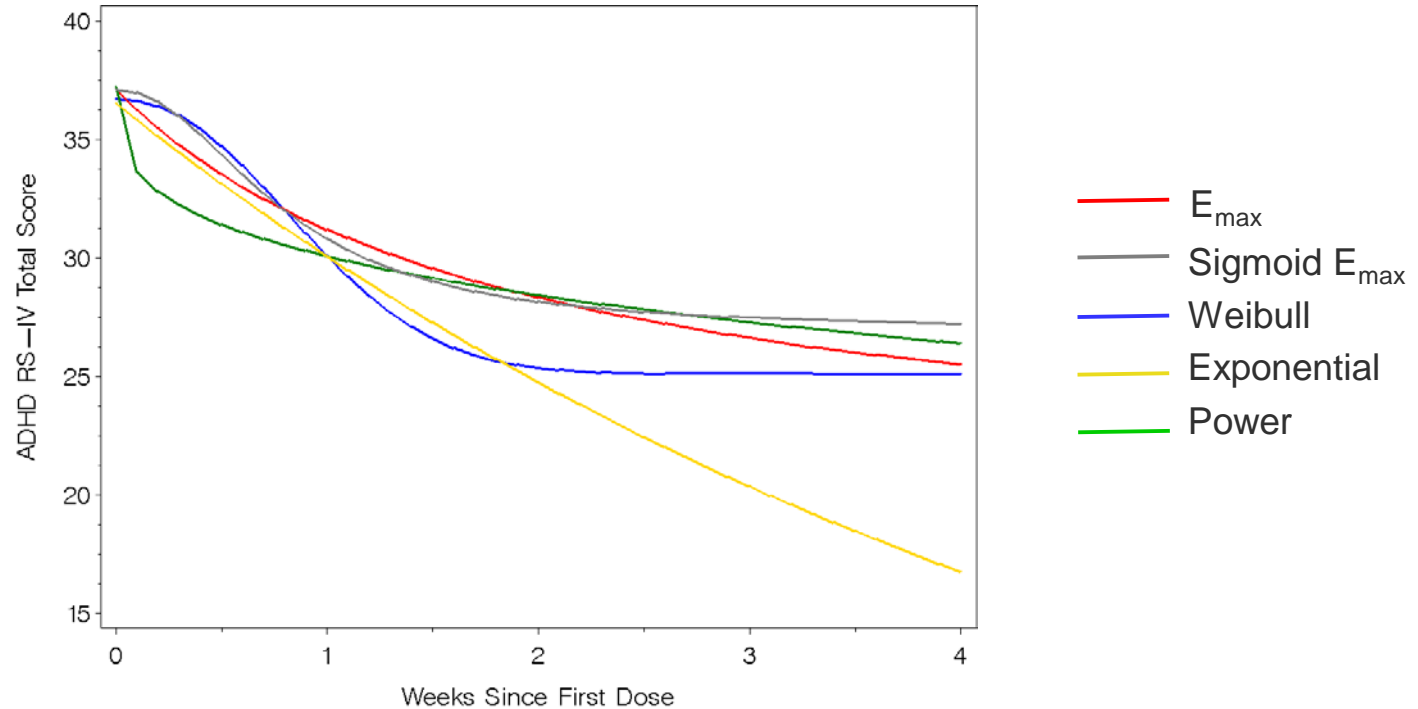

# ADHD Placebo Response Model

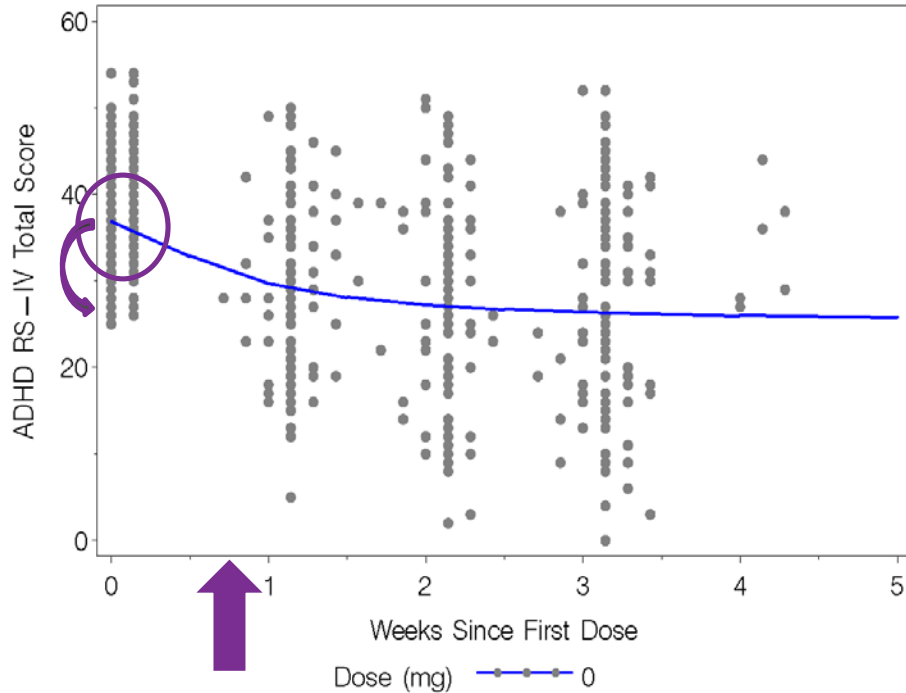

- Best placebo model: Sigmoid  $E_{\max}$  function of time

$$\text{Placebo ADHD RS-IV}_{ij} = 36.8 + \frac{(-11.5 \times \text{Week}_{ij}^{1.63})}{(0.743^{1.63} + \text{Week}_{ij}^{1.63})}$$

# E-R ADHD Model

- Effect of dasotraline  $C_{av}$  on  $E_{max}$  was best predictor and was evaluated using **linear** and power functions
- No statistically significant covariates were identified ( $\alpha = 0.01$  forward;  $\alpha = 0.001$  backward)
- Final E-R Model: sigmoid  $E_{max}$  function of time with  $E_{max}$  linear function of  $C_{av}$

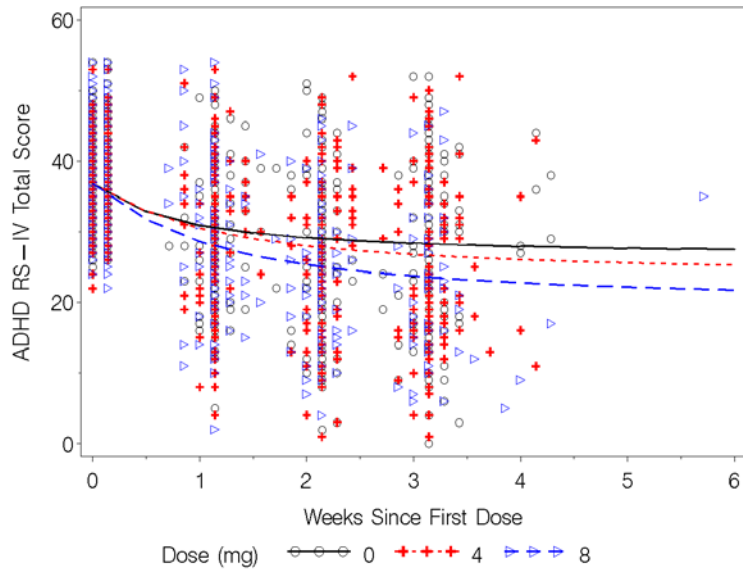

The lines represent the sigmoid  $E_{max}$  model for each dose.

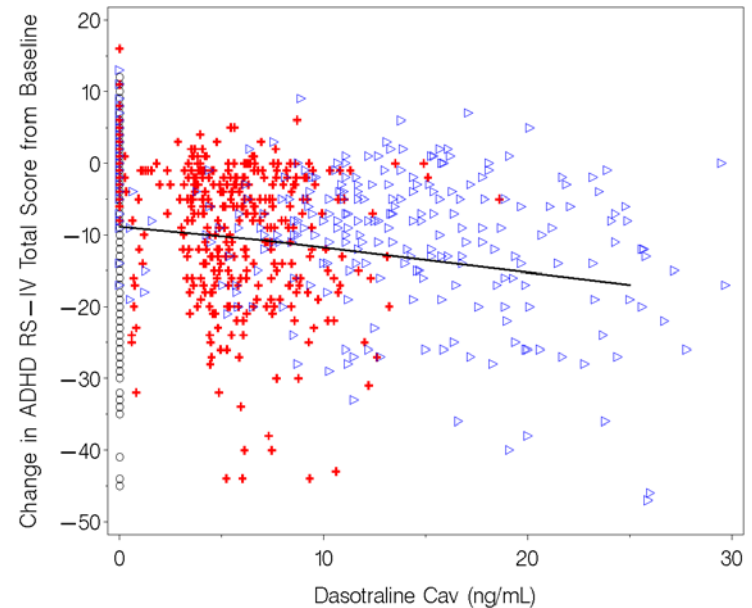

# Clinical Trial Simulation Methodology

- Goal: determine optimal study design and dosing regimens for Phase 3 dasotraline trial in adults
- Final population PK and E-R ADHD RS-IV total score models were used as basis for simulations using NONMEM
- 500 replicated clinical trials



# Clinical Trial Simulation Methodology, cont'd

- Design characteristics
  - Maximum of 12-week duration of treatment
  - Sample size = 150/200/300 per arm in 1:1 ratio treatment:placebo
  - Treatment regimens
    - Placebo once daily
    - Active doses: 2, 4, 6, or 8 mg/day
  - ADHD RS-IV total score measurements collected on Day 1 (baseline) and weekly for 12 weeks
  - Inclusion criteria: All patients must have ADHD RS-IV with adult prompts total score  $\geq 26$  and Clinical Global Impressions-Severity (CGI-S) score  $\geq 4$  at baseline (Day 1)

# Clinical Trial Simulation Methodology, cont'd

- Primary efficacy endpoint: change from baseline (Day 1) to end-of-treatment phase (Week 8) in ADHD RS-IV total score
  - Active treatment and placebo compared for each simulated trial
- Study dropout was incorporated using time-to-study-dropout model developed on Phase 2 adult data
  - Two separate scenarios for dropout were considered:
    - 1) retaining dropout rates for each dose level observed in Phase 2 for first 4 weeks
    - 2) allowing additional amount of fixed dropout on Week 6 through Week 12

# Clinical Trial Simulation Methodology, cont'd

- Mixed effects model for repeated measures (MMRM) including treatment, visit (as categorical variable), baseline ADHD RS-IV total score, and treatment-by-visit interaction
  - Unstructured covariance matrix for within-patient correlation
  - Kenward-Roger approximation used to estimate denominator degrees of freedom
- MMRM model fit to each virtual trial

# Clinical Trial Simulation Methodology, cont'd

- P-value calculated for the comparison of ADHD RS-IV responses between active and placebo treatment
- P-values  $< 0.05$  were considered statistically significant
- For each design, % of trials with statistically significant difference in primary endpoint between placebo and active treatment arms was summarized as probability of success

# Clinical Trial Simulation Process

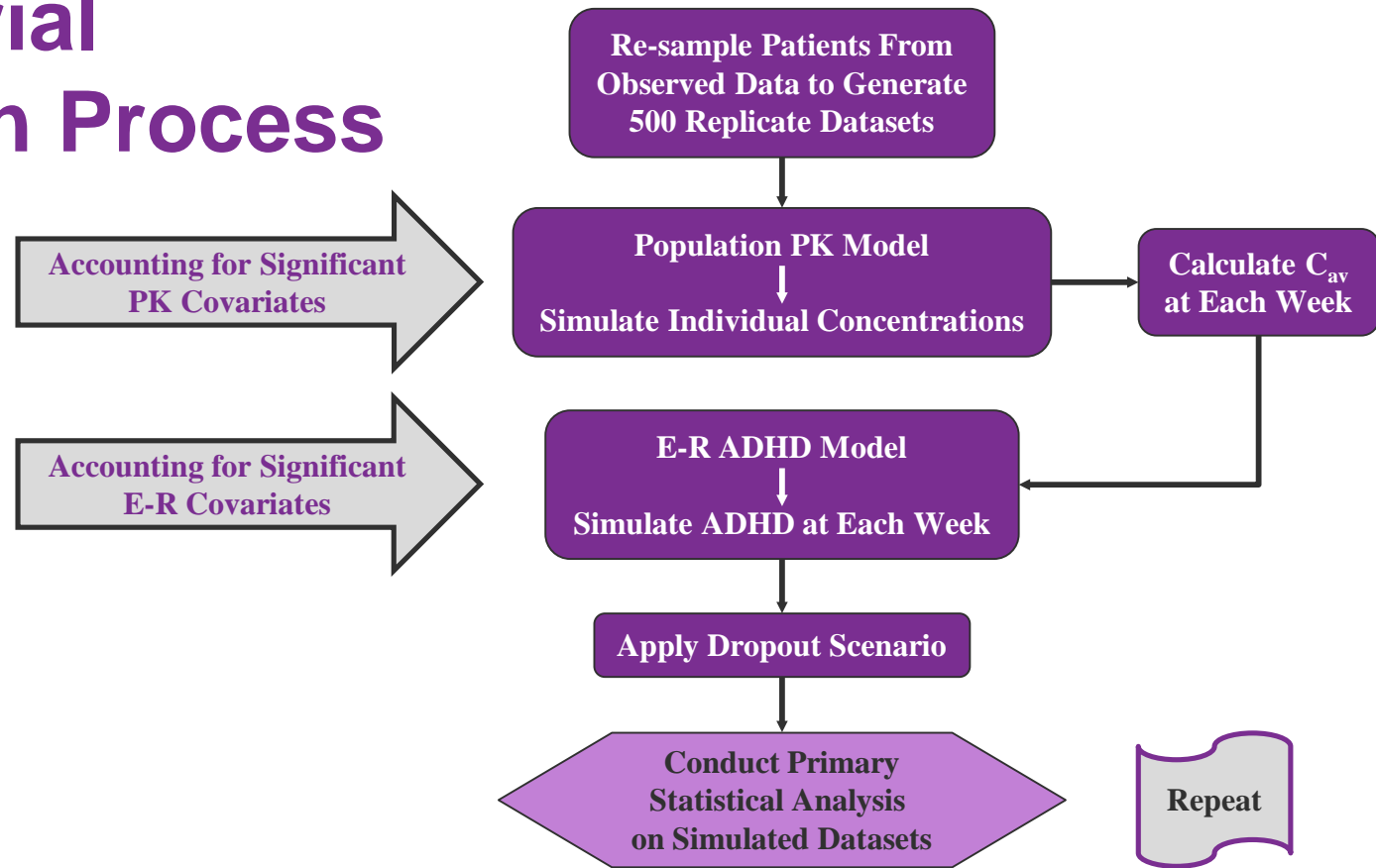

Determine P(success) based on significance of replicate trials.

# Clinical Trial Simulation Results

## Sample Size Evaluation at End of Treatment (Week 8)

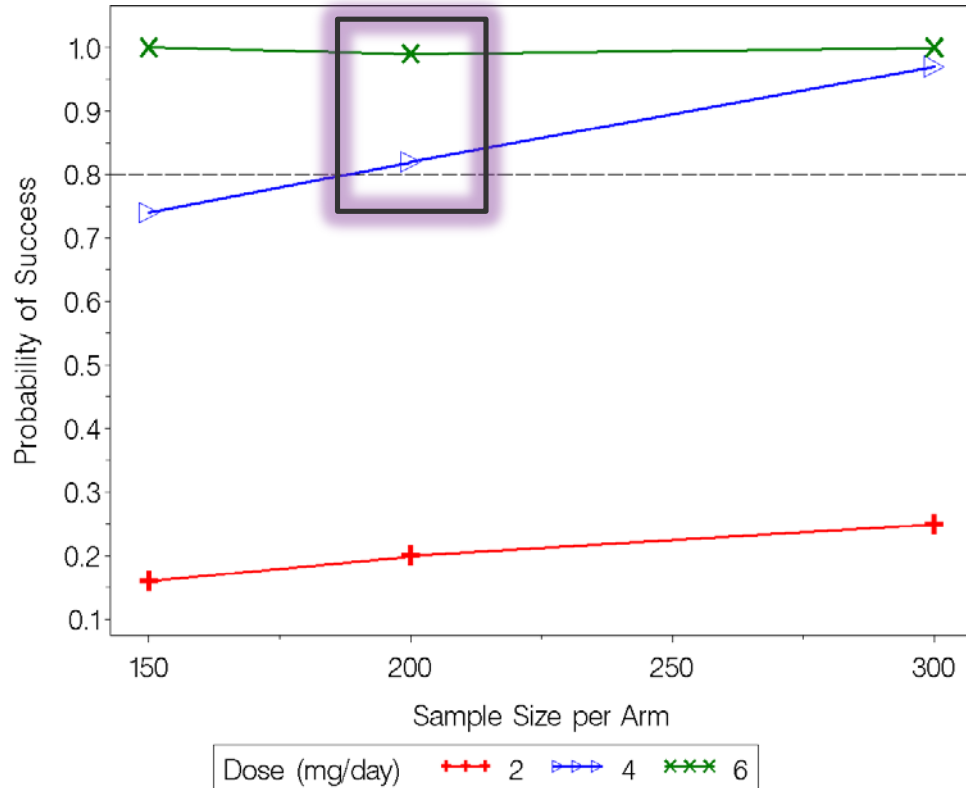

# Clinical Trial Simulation Results

## Duration and Doses

- 8-week duration sufficient
- 4 and 6 mg dasotraline meet 80% criteria

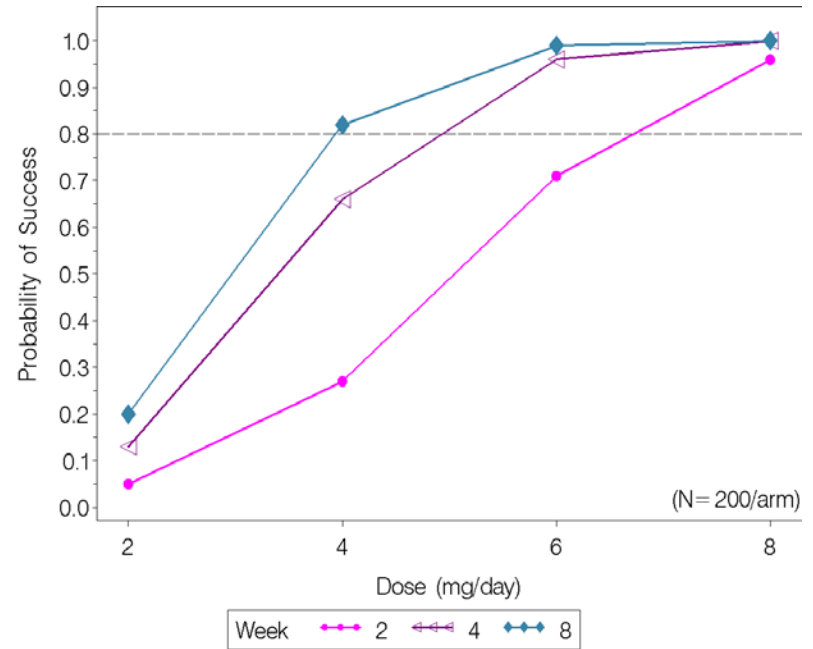
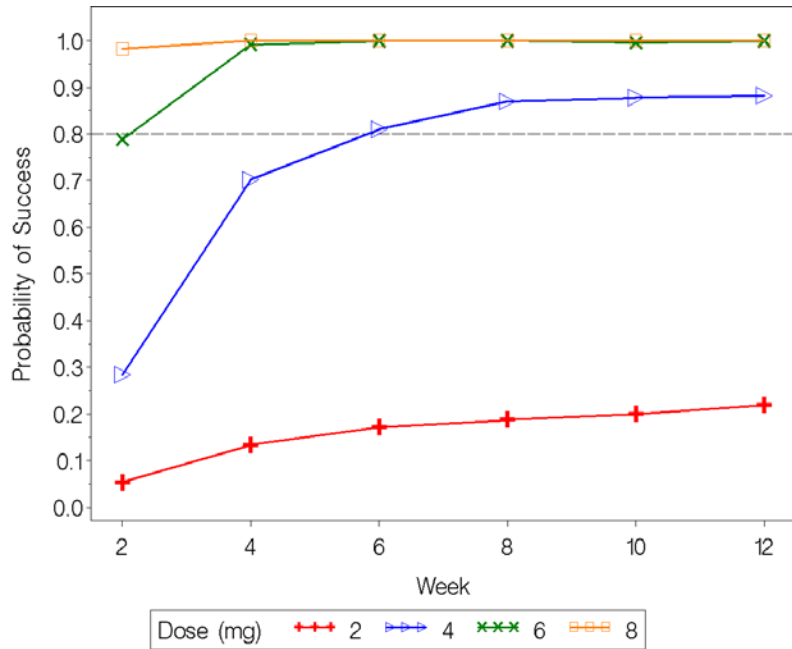

# Phase 3 Trial Results

- Randomized, double-blind, multicenter, parallel-group, outpatient study evaluating efficacy and safety of 2 doses of dasotraline (4 or 6 mg/day) versus placebo in adults with ADHD over 8-week treatment period
- Approximately 600 patients, randomized to 3 treatment groups in 1:1:1 ratio
- Findings
  - Placebo response quite different between Phase 2 and Phase 3 (at Week 1 through Week 4)
  - Placebo response in Phase 3 continues to Week 6 then plateaus
  - Magnitude of placebo response 2-fold higher in Phase 3 at end of treatment

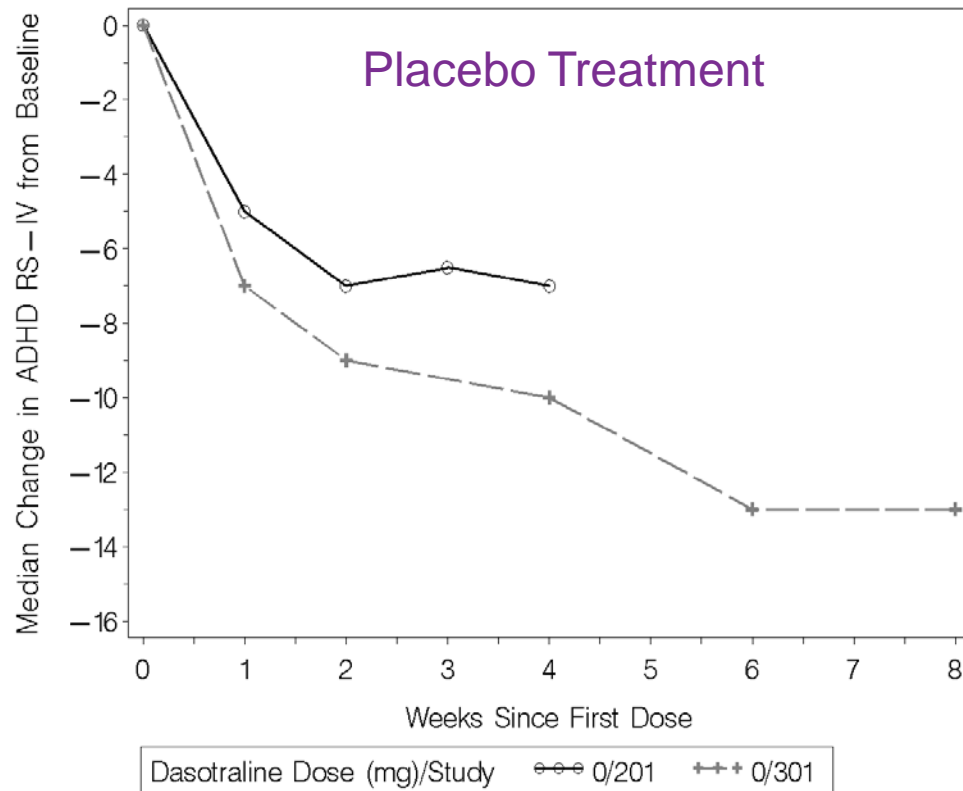



# Phase 3 Trial Results, cont'd

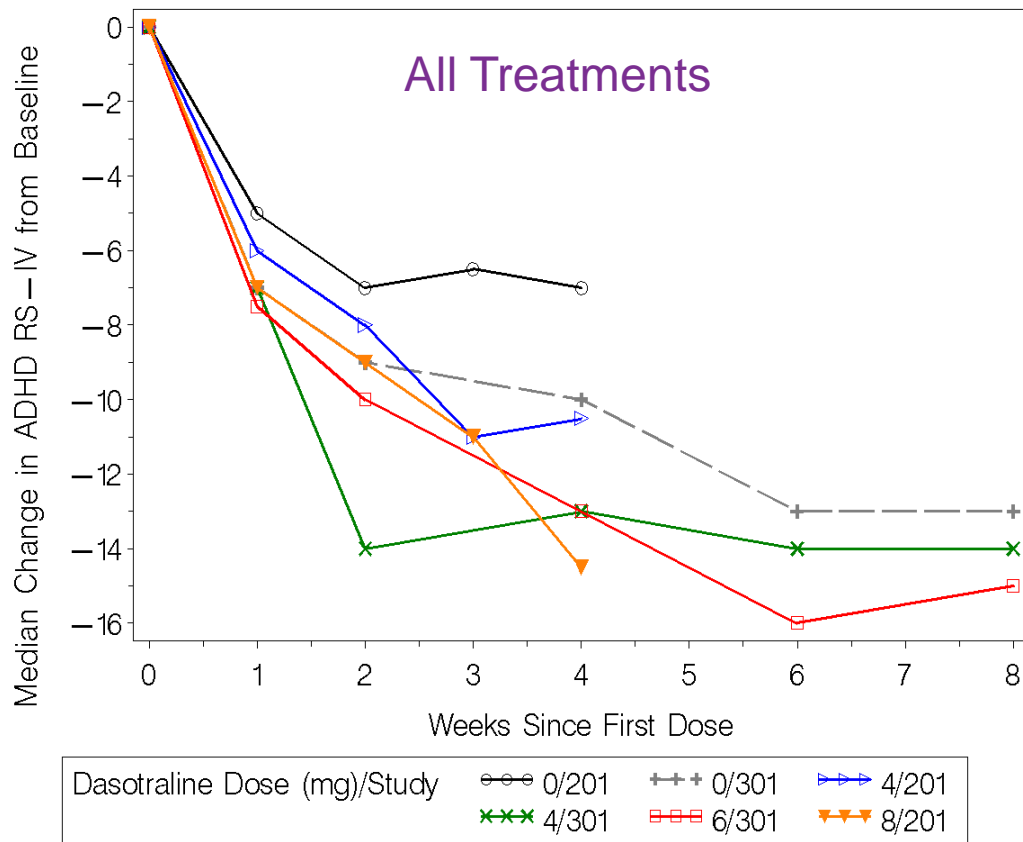

# Phase 3 Trial Results, cont'd

## Sunovion Announces Top-line Results from Studies Evaluating Dasotraline in Adults with Binge Eating Disorder and Attention Deficit Hyperactivity Disorder

*– Clinical development program continues for dasotraline in binge eating disorder (BED) and attention deficit hyperactivity disorder (ADHD) –*

January 13, 2017 08:30 AM Eastern Standard Time

MARLBOROUGH, Mass.--(BUSINESS WIRE)--Sunovion Pharmaceuticals Inc. (Sunovion) today announced that a Phase 2/3 study (SEP360-221), the first of two planned pivotal studies, evaluating its novel drug candidate dasotraline in adults ages 18 to 55 years with moderate to severe binge eating disorder (BED) met the primary efficacy endpoint as well as all key secondary efficacy endpoints.<sup>1</sup> Sunovion also announced that the Phase 3 study (SEP360-301) evaluating dasotraline in adults ages 18 to 55 years with attention deficit hyperactivity disorder (ADHD) did not meet its primary endpoint.

In study SEP360-301, fixed doses of dasotraline 4 mg/day and 6 mg/day did not demonstrate statistically significant improvement at the 8 week primary endpoint on the ADHD Rating Scale (RS) IV (with adult prompts) total score compared to the placebo-treated group.<sup>1</sup> A trend toward greater improvement for the 6 mg/day group at study endpoint compared to placebo was observed ( $p=0.074$ ). Statistically significant improvement on the CGI-S was observed for the 6 mg/day group (but not the 4 mg/day group) at study endpoint ( $p=0.011$ ). While the overall improvement associated with the dasotraline treatment groups was consistent with prior studies, a relatively large improvement was seen in the placebo group on the ADHD RS-IV, which may have contributed to the observed lack of statistical separation at primary endpoint.

<https://www.businesswire.com/news/home/20170113005290/en/Sunovion-Announces-Top-line-Results-Studies-Evaluating-Dasotraline>

# Does the Increasing Placebo Response Impact Outcomes of Adult and Pediatric ADHD Clinical Trials? Data From the US Food and Drug Administration 2000-09

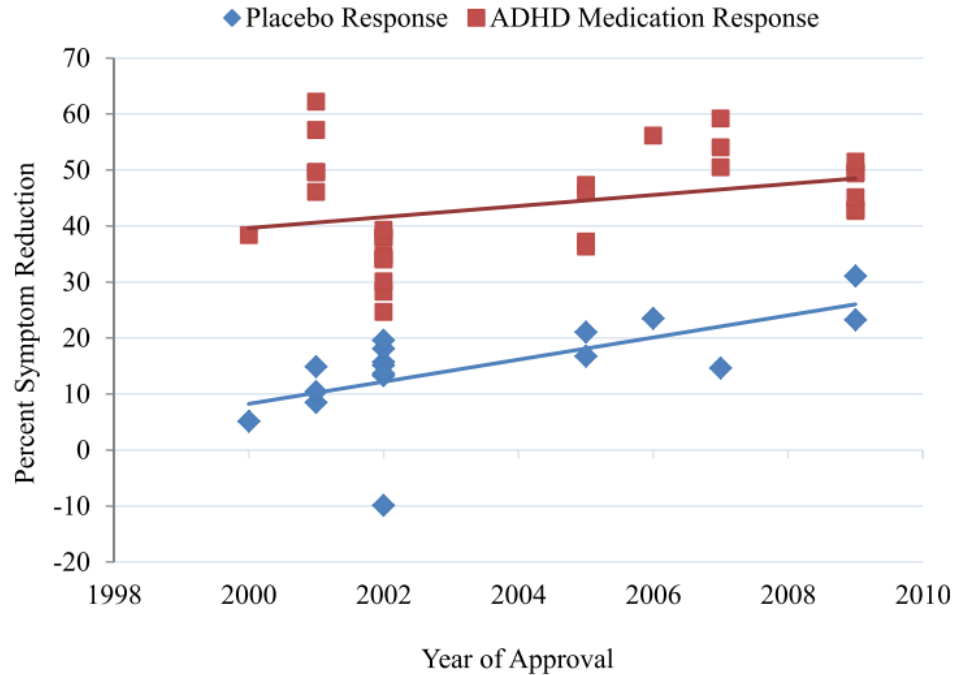

- Placebo response has increased by more than double from ~10% to ~25% over 10 years

**Fig. 1.** Scatterplot of percent symptom reduction in 17 placebo group treatment arms and in 29 antidepressant group treatment arms from 17 clinical trials for 10 ADHD investigational medication approval programs plotted with year of approval.

# Importance of Placebo Response Assessment

- Data from placebo treatment used as comparator arm for testing statistical significance
- Must be able to quantify placebo response adequately
  - In longitudinal models, need placebo response data over time
- Consider variability in placebo response over time (duration) and across studies
  - May need to consider historical placebo response data or placebo response data from comparators

# What Could We Have Done Better?

- Simulate sensitivity around Phase 2 observed placebo response
- Consider impact of increased placebo response on effect size and, ultimately, sample size
  - Planned sample size was 120 patients per arm, increased to 200 patients per arm due to simulations
- Consider adding placebo run-in period in Phase 3 study to identify and weed out placebo responders and minimize placebo response
- Consider stricter inclusion criteria for baseline disease markers

# References

1. Hopkins SC, Sunkaraneni S, Skende E, Hing J, Passarell JA, Loebel A, et al. Pharmacokinetics and exposure-response relationships of dasotraline in the treatment of attention-deficit/hyperactivity disorder in adults. Poster presented at: American Conference on Pharmacometrics (ACoP): October 4-7, 2015; Crystal City, VA.
2. Hopkins SC, Sunkaraneni S, Skende E, Hing J, Passarell JA, Loebel A, et al. Pharmacokinetics and exposure-response relationships of dasotraline in the treatment of attention-deficit/hyperactivity disorder in adults. Clin Drug Investig. 2016 Feb;36(2):137-46.

# Thank you

## Acknowledgements

Jill Fiedler-Kelly

Seth Hopkins

Sandra Cohen

Jeremy Hing

Ken Koblan

Gerry Galluppi

Soujanya Sunkaraneni

# BACKUP SLIDES



# Methodology - Population PK Model

- Dasotraline population PK model was developed using 4570 dasotraline measurements in 395 subjects after single or multiple administrations of dasotraline in doses ranging from 0.2 to 36 mg
- Data from 3 intensely sampled Phase 1 studies and sparse samples from Phase 2 study in ADHA patients were pooled for population PK analysis
- In addition to body weight, which was included as part of base PK model, additional demographic and clinical covariates were evaluated including age, total bilirubin, alanine aminotransferase (ALT), sex, race, and ethnicity
- Final population PK model was validated using simulation-based, pcVPC methodology
- Population PK model was used to generate empiric Bayesian PK parameter estimates for each individual in analysis datasets
- Individual measures of dasotraline exposure (for example,  $C_{av}$ ,  $AUC_{0-24}$ ,  $C_{min}$ , and  $C_{max}$ ) were calculated by numerical integration using developed population PK model for dasotraline and associated individual-specific parameter estimates with NONMEM, Version 7, Level 1.22
- Model-predicted exposure measures obtained for each patient at each week were utilized in development of PK/PD model to describe E-R relationship for ADHD RS-IV with adult prompts total scores

# Population PK Model Results

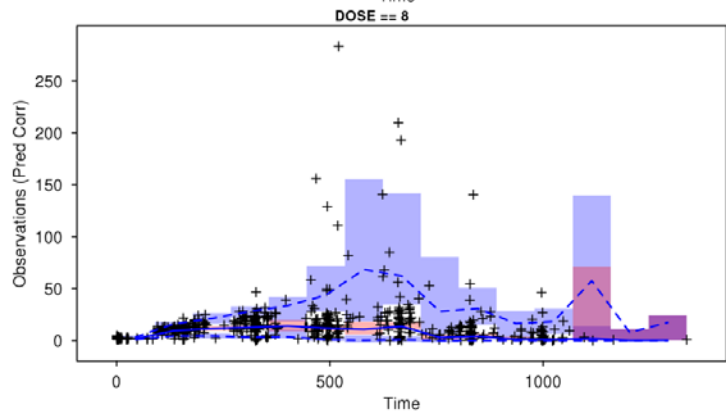
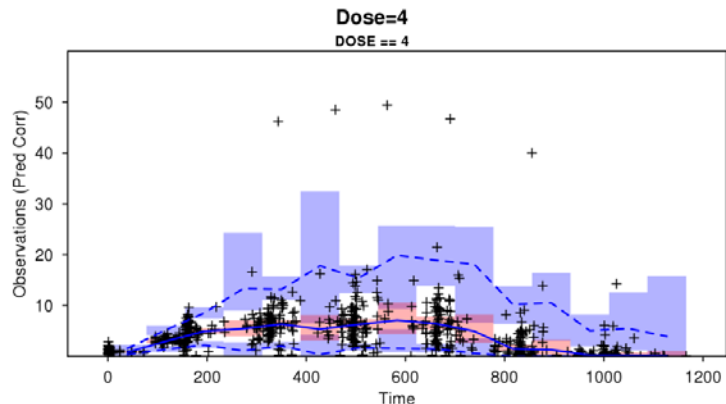

Data: + Observations  
Predictions: — Median — — 5<sup>th</sup> and 95<sup>th</sup> percentiles  
95% CI of predictions percentiles  
Medians and percentiles are plotted at the midpoint of each time interval.

- A 1-compartment population PK model with sequential zero-order followed by first-order absorption and dual (nonlinear and linear) elimination
- Linear apparent clearance was found to be time dependent following inclusion of Phase 2 data; this allowed the linear portion of apparent clearance (CL/F) to increase over time with multiple-dose administration
- CL/F was estimated to increase with values ranging from 4.95 to 8.16 L/h in Phase 1 and to 15.0 L/h in multiple-dose efficacy study
- Nonlinear CL/F represented saturable elimination pathway operating at approximately 50% of its capacity based on estimate of Michaelis-Menten constant at lower dasotraline concentrations of around 1.7 ng/mL
- As concentrations increased above 3.0 ng/mL, nonlinear component contributed less to total elimination
- Weight was only covariate found to be associated with variability in population PK model

# Population PK Model Results

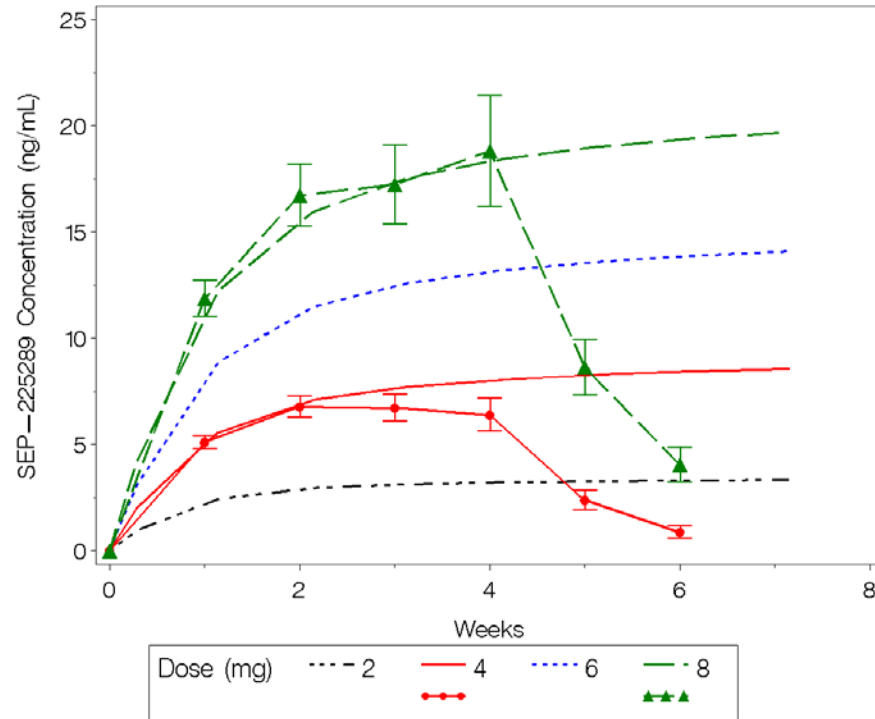

# Population PK Model Results

Parameter	Final Parameter Estimate		Interindividual Variability / Residual Variability	
	Typical Value	%SEM	Magnitude	%SEM
$k_a$ : Rate of absorption (1/h)	1.43	7.95	87.7 %CV	16.2
D1: Duration of zero-order absorption (h)	6.38	3.09	32.4 %CV	16.2
V/F: Apparent volume of distribution (L)	2800	1.33	18.1 %CV	10.9
$V_{max}$ : Maximum elimination rate (mg/h)	0.0495	4.02	0 %CV	FIXED
$K_m$ : Michaelis-Menten constant (mg)	4.74	5.42	41.6 %CV	16.2
CLind <sub>1</sub> : Induced apparent oral clearance Phase 1 (L/h)	8.16	12.4	NE	NE
Ratio of additive/proportional component of RV Phase 1	0.0218	5.97	NE	NE
Ratio of additive/proportional component of RV Phase 2	0.194	9.50	NE	NE
Power of weight on V	0.777	7.89	NE	NE
Power of weight on CLind	1.18	13.4	NE	NE
Power of weight on CLint	1.64	33.8	NE	NE
CLint: Apparent oral clearance intercept (L/h)	4.95	13.1	NE	NE
Rate of induction (1/h)	0.00644	34.2	NE	NE
CLind2: Induced apparent oral clearance Study 306-201 (L/h)	15.0	7.54	NE	NE
IIV on CL	N	NA	69.6 %CV	6.11
Proportional RV PH1	0.0244	1.55	69.9 - 15.6 %CV F [0.0050 - 25]	NA
Proportional RV PH2	0.0714	3.59	1040 - 26.7 %CV F [0.0050 - 25]	NA
Minimum value of the objective function = -4709.279				

# E-R ADHD Model

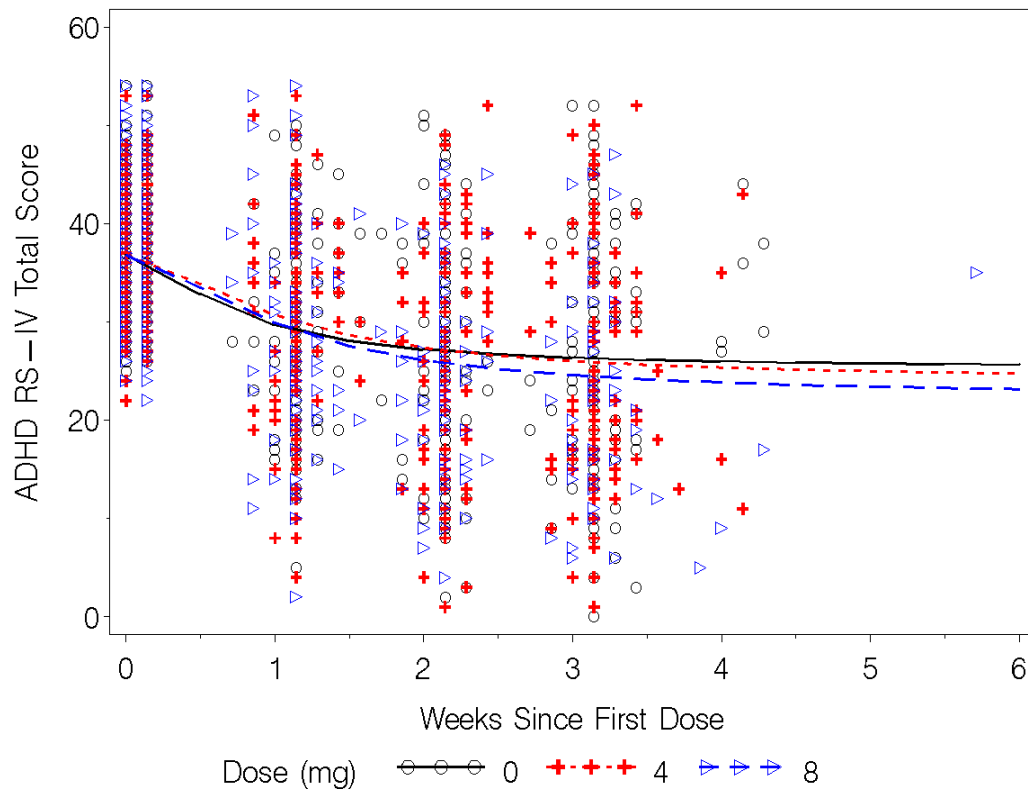

The lines represent the sigmoid Emax model for each dose.

# E-R ADHD Model

## Parameter Estimates

Parameter	Final Parameter Estimate		Interindividual Variability / Residual Variability	
	Typical Value	%SEM	Magnitude	%SEM
BL: Baseline ADHD RS-IV with adult prompts total score	36.8	0.991	5.98 SD	8.08
$E_{\max}$ : Maximum reduction in ADHD RS-IV with adult prompts total score due to time	-10.2	8.90	9.23 SD	10.3
T50: Time producing 50% of $E_{\max}$ for placebo (weeks)	0.762	10.9	43.2 %CV	18.6
T50A: Time producing 50% of $E_{\max}$ for 4 and 8 mg (weeks)	1.08	7.79		
SLP: Slope for $C_{av}$ on $E_{\max}$	-0.422	26.2	NE	NE
S: Hill coefficient	1.14	11.3	114 %CV	28.1
cov(IIV) on S, IIV on $E_{\max}$ )	-6.24	19.1	NA9)	NA
Residual variability	15.9	8.87	3.98 SD	NA
Minimum value of the objective function = 8585.916				

# E-R Time to Study Dropout Model

- 8228 daily records from 330 subjects from Study SEP360-201 were included
- A semi parametric Cox proportional hazard model relating dasotraline Cav and the interaction between Cav and time to the log of the survival function for dropout
- Influence of Cav on the risk of study dropout (hazard ratio of 1.24, 95% CI=1.12, 1.36) indicates that with increasing Cav the predicted risk of study dropout increases
- The risk of study dropout is reduced by approximately 8 fold when comparing the hazard ratio for 8 mg to 4 mg assuming the median Cav for each dose.
- Clinical trial simulations of 200 virtual subjects predict 0%, 15%, and 45% of subjects will drop

# E-R Time to Study Dropout Model

- CTS of 200 virtual subjects predict 9%, 15%, and 45% of subjects will drop out of the study on Day 28 for placebo, 4 mg, and 8 mg, based on time and average concentration using the Cox proportional hazard model
  - These model predicted values are concordant with the observed dropout rate on Day 28 in Study SEP360-201
- Higher SEP-225289  $C_{av}$  was statistically significantly associated with a higher risk of study dropout
- VPC results indicate no apparent bias in the first 3 weeks; however the model under predicts dropout in the last week for the highest exposures
- No covariates were found to be a statistically significant predictor of variability in the dropout rate
  - age, baseline weight, baseline BMI, baseline ADHD RS IV with adult prompts total score, baseline DHPG, baseline heart rate (standing and supine), insomnia severity index (baseline and time varying), gender, race, and ethnicity



# E-R Time to Study Dropout Model

## VPC Plot

